



Article history:
Received 20 February 2024
Revised 22 March 2024
Accepted 07 April 2024
Published online 01 July 2024

Designing a Model of Collective Identity Based on Perceived Social Support with the Mediating Role of Emotional Intelligence in Students of Qom Province

Masoumeh. Shafae¹, Fatemeh. Shaterian Mohammadi^{2*}, Alireza. Zolfaghari³

¹ PhD student, Department of Educational Psychology, Arak Branch, Islamic Azad University, Arak, Iran.

² Assistant Professor, Department of Educational Psychology, Saveh Branch, Islamic Azad University, Saveh, Iran.

³ Assistant Professor, Department of Psychology and Educational Sciences, Tuiserkan Branch, Islamic Azad University, Tuiserkan, Iran.

* Corresponding author email address: fa.shaterian@iau.ac.ir

Article Info

Article type:

Original Research

How to cite this article:

Shafae, M., Shaterian Mohammadi, F., Zolfaghari, A. (2024). Designing a Model of Collective Identity Based on Perceived Social Support with the Mediating Role of Emotional Intelligence in Students of Qom Province. *Iranian Journal of Educational Sociology*, 7(3), 71-79.

<http://dx.doi.org/10.61838/kman.ijes.7.3.9>



© 2024 the authors. Published by Iranian Association for Sociology of Education, Tehran, Iran. This is an open access article under the terms of the Creative Commons Attribution-NonCommercial 4.0 International (CC BY-NC 4.0) License.

ABSTRACT

Purpose: Considering the significance of collective identity in carrying out group and social activities, this study aimed to design a model of collective identity based on perceived social support with the mediating role of emotional intelligence among students.

Methodology: The present study was applied in objective and descriptive-correlational in method. The research population comprised all undergraduate psychology students of the Islamic Azad University of Qom Province in the academic year 2021-2022. The sample size of this study was 500 individuals, selected after reviewing the entry criteria through convenience sampling. Data were collected using the Collective Identity questionnaire (Hezarjaribi & Lohrasbi, 2011), Perceived Social Support (Sherbourne & Stewart, 1991), and Emotional Intelligence (Schering, 1996) questionnaires and analyzed using Pearson correlation coefficients and structural equation modeling in SPSS-27 and AMOS-24 software.

Findings: The findings showed that collective identity, perceived social support, and emotional intelligence among students had a positive and significant correlation ($P < 0.01$). Additionally, the model of collective identity based on perceived social support with the mediating role of emotional intelligence in self-efficacy among students had an appropriate fit. In this model, the variable of perceived social support had a direct and significant effect on emotional intelligence and students' collective identity, and the variable of emotional intelligence had a direct and significant effect on their collective identity. Perceived social support with the mediating role of emotional intelligence had an indirect and significant effect on students' collective identity ($P < 0.001$).

Conclusion: According to the results of the present research, counselors and psychologists can improve collective identity among students by enhancing their perceived social support and emotional intelligence through educational workshops.

Keywords: *Collective identity, Perceived social support, Emotional intelligence, Students.*

1. Introduction

Throughout human history, identity has been examined from various perspectives and is considered a social entity and the product of individual interactions with others. Thus, the self is shaped through understanding and relating to others during the socialization process (Mackay et al., 2021). Identity encompasses both individual and collective aspects, where individual identity includes aspects that distinguish the individual from others, whereas collective identity encompasses aspects shared with others (Bein, 2022). The concept of identity is rooted in sociology and connects with the concepts of self and other. Consequently, collective identity gains meaning through differentiation from self and others, and the formation of the self in relation to others is the basis for individuals' collective identity formation (Kann et al., 2023). Collective identity represents indicators of a group or community to which individuals belong, commit themselves, and through which they identify themselves (Ulug et al., 2021). Collective identity includes ethnic, national, and transnational or cosmopolitan aspects, where ethnic identity represents a group of people who see themselves as distinct from other societal groups, enhancing intra-group or ethnic cohesion. National identity signifies a sense of solidarity with a larger national community, awareness of it, and loyalty and sacrifice for it. Transnational or cosmopolitan identity represents a commitment and belonging to the world as a whole (Hezarjaribi & Lohrasbi, 2011).

One of the factors influencing collective identity is perceived social support (Häusser et al., 2023), which is a multidimensional and complex construct meaning the extent to which an individual receives affection, companionship, care, respect, attention, and assistance from others (Millwood & Manczak, 2023). In another definition, social support means acquiring information, material aids, plans, or health recommendations and emotional support from those the individual cares about or values (Buursma et al., 2020). Perceived social support is seen as a supportive network in the form of received and perceived support, referring to an individual's mental assessment of the extent of support received from others. Individuals with social support show higher resilience and flexibility against stressors and enjoy better health and quality of life (Babanejad et al., 2020). Perceived social support represents the extent of affection, companionship, and attention received from family members, friends, public arrangements of society, and other individuals (Torun et al., 2021). This construct refers to the

explicit informational, emotional, and instrumental responses that, by creating a sense of belonging and attachment to others, improve quality of life, promote health-related behaviors, and increase life satisfaction (Liu et al., 2023). Perceived social support acts like an effective and efficient coping strategy, neutralizing psychological pressures, preventing the increase of undesirable physiological and psychological outcomes, and reducing anxiety and depression (Ayar & Sabancioğullari, 2022). The support is offered as psychological and emotional, informational, tangible, and social support, and the individual's perception of support is significantly important, more so than the support itself. Therefore, the amount of perceived social support is determinative, not the number of relationships and visible supports, thus the mental and psychological aspect of this type of support is more significant compared to its apparent aspect (Xiao et al., 2022).

Emotional intelligence is one of the variables that can mediate between perceived social support and collective identity. This intelligence includes a collection of emotions, abilities, and emotional and social knowledge that enhances an individual's capability to manage environmental stresses (White et al., 2023). Emotion, as a psychological construct, involves cognitive appraisal, motivation, and situation, and emotional intelligence is a type of emotional information processing that includes accurate appraisal of one's own and others' emotions, correct expression of emotions, and adaptive and harmonious regulation of emotions (Encinas & Chauca, 2020). Emotional intelligence means the ability to monitor one's and others' feelings and emotions, distinguish between them, and ultimately use this information to guide thoughts and actions, playing an effective role in improving emotional, social, and cognitive performances (Masoumparast et al., 2019). This intelligence implies the capability and capacity to perceive, express, recognize, apply, and manage one's own and others' emotions, leading to arousal, resistance against frustrations, impulse control and delay of gratifications, mood regulation, and empathy with others (Malik, 2021). Emotional intelligence includes five components: self-awareness, self-management, self-motivation, social skills, and social awareness; where self-awareness means awareness of one's psychological states and thinking about them, self-management means an individual's ability in adaptation, initiative, desire for success, work ethic, internal confidence, flexibility, and a comprehensive attitude towards coordinating with others' feelings, self-motivation means suppressing frustrations and

worries that discourage the individual from continuing work and thereby increasing their motivation for continuing activities, social skills mean abilities in recognizing others' emotions and feelings, listening to others' emotions and feelings, and social awareness means recognizing and being aware of one's relationships with others and the necessity for ethical decision-making and empathy for establishing connections (Li et al., 2021).

Few studies have been conducted on the relationships between perceived social support, emotional intelligence, and collective identity, and the following are the results of the most significant domestic and international researches. The study by Azpiazu, Antonio-Agirre, Fernandez-Zabala, and Escalante (2023) showed that there was a positive and significant correlation between social support, emotional intelligence, and life satisfaction among middle school students (Azpiazu et al., 2023). Ullah et al. (2023) found that social support and emotional intelligence had a significant positive relationship and social support had a significant negative relationship with academic stress (Ullah et al., 2023). Another study by Ghazvineh et al. (2023) reported that emotional intelligence had a direct and significant effect on perceived social support among high school students (Ghazvineh et al., 2022). Taleghaninejad, Davari, and Lotfikashani (2021) found that perceived social support and emotional intelligence had a significant positive correlation among high school students (Taleghaninejad et al., 2021). Additionally, the study by Hausser et al. (2023) showed that there was a significant relationship between social support and social identity over a 13-month period during which both variables were assessed four times (Häusser et al., 2023). Another study by Majdi, Ramezani, and Azimi Hashemi (2016) reported that there was a significant relationship between social support and identity formation in martyr children (Majdi et al., 2016). Haslam, O'Brien, Jetten, Vormedal, and Penna (2005) found that there was a significant positive relationship between social support and social identity and a significant negative relationship between social support, social identity, and the experience of stress (Haslam et al., 2005). Additionally, the study by Esmailishad, Soleimanpour Omran, and Soheilifar (2021) showed that social identity had a direct and significant effect on the emotional or emotional intelligence of preschool teachers (Esmailishad et al., 2021). Another study by Canto and Vallejo-Martin (2021) reported that emotional connection had a direct and significant effect on the mental well-being and social identity of women and men during the

fight against the COVID-19 pandemic (Canto & Vallejo-Martin, 2021).

One of the sectors and institutions where knowledge sharing is very important is higher education, and students are one of the most important members of this educational system, playing an effective role in producing, creating, and changing knowledge. Therefore, research on students is very important. Given the importance of the university as one of the elements and modern institutions for enhancing specialized and general knowledge, philanthropy, universalism, and strengthening the public sphere, examining and evaluating the role of the university environment in rethinking identity is very important and significant. Additionally, the necessity of this study stems from the fact that identity is a necessary condition for social life, and humans cannot meaningfully, desirably, and stably establish connections with others without having a framework for determining their collective identity and meeting their various physical and psychological needs. One of the challenges students face is the challenge of identity, and given the importance of collective identity in carrying out group activities, very few studies have been conducted on collective identity, and no study has designed a model for it based on perceived social support with the mediation of emotional intelligence. Therefore, there are many gaps in this area, and experts and higher education planners can take effective steps to improve collective identity and its consequences based on the results of this study and similar studies. Consequently, given the importance of collective identity in carrying out group and social activities, this study aimed to design a model of collective identity based on perceived social support with the mediating role of emotional intelligence among students.

2. Methods and Materials

2.1. Study Design and Participants

The present study was applied in objective and descriptive-correlational in method. It is correlational because it examines the relationships between variables. The research population included all undergraduate psychology students at the Islamic Azad University of Qom Province for the academic year 2022-2023. The sample size of this study was 500 individuals, selected after reviewing the entry criteria through convenience sampling. The entry criteria for this study included being an Iranian student residing in Qom province, not suffering from specific psychiatric diseases, not using psychiatric drugs, willing to participate in the

research, and not experiencing stressful events such as divorce or the death of relatives in the past three months. Additionally, exclusion criteria included inappropriate completion of questionnaires and withdrawal from completing them.

The procedural steps of the current research began with the approval of the research proposal at the Islamic Azad University, Arak branch, followed by a letter regarding collaboration with the first researcher to conduct research on undergraduate psychology students at the Islamic Azad University of Qom Province from the research unit of the Islamic Azad University, Arak branch. Subsequently, visits were made to the Islamic Azad Universities in Qom Province offering psychology programs, where the importance and necessity of the research were explained to university officials and students, who were then invited to participate in the study if they met the above-mentioned entry criteria and to respond to the current research questionnaires. Finally, undergraduate psychology students were acknowledged and thanked for participating in the research and completing the questionnaires.

2.2. Measures

2.2.1. Collective Identity

Developed by Hezarjaribi & Lohrasbi (2011) with 30 items across three dimensions: ethnic identity, national identity, and transnational or cosmopolitan identity (10 items each). Responses were recorded on a five-point Likert scale ranging from very low (score of 1) to very high (score of 5). The total score is calculated by summing the scores of all 30 items, with a minimum score of 30 and a maximum score of 150, where higher scores indicate a more favorable collective identity. They reported acceptable face validity and a Cronbach's alpha reliability of 0.82 (Hezarjaribi & Lohrasbi, 2011). The reliability of the Collective Identity Questionnaire in the current study was calculated using Cronbach's alpha, through the correlation coefficient between its items, as 0.90.

2.2.2. Perceived Social Support

Developed by Sherbourne & Stewart (1991) with 19 items across five dimensions: tangible support, emotional support, informational support, affection, and positive social interaction (4, 4, 4, 3, and 3 items respectively) plus one item

contributing to the overall questionnaire score but not included in any of the five dimensions. Responses were recorded on a five-point Likert scale from never (score of 1) to always (score of 5). The total score is calculated by summing the scores of all 19 items, with a minimum score of 19 and a maximum score of 95, where higher scores indicate higher and more favorable perceived social support. They confirmed construct validity and obtained a Cronbach's alpha reliability of 0.88. In Iran, Ahmadi Sarvandi & Amoopour (2023) reported a total reliability of 0.79 using Cronbach's alpha (Ahmadi & Amoopour 2023). The reliability of the Perceived Social Support Questionnaire in the current study was calculated using Cronbach's alpha, through the correlation coefficient between its items, as 0.95.

2.2.3. Emotional Intelligence

Developed by Schering (1996) with 33 items across five dimensions: self-awareness, self-management, self-motivation, social skills, and social awareness (8, 7, 7, 5, and 6 items respectively). Responses were recorded on a five-point Likert scale from never (score of 1) to always (score of 5). The total score is calculated by summing the scores of all 33 items, with a minimum score of 33 and a maximum score of 165, where higher scores indicate higher and more favorable emotional intelligence. The construct validity was confirmed, and reliability was obtained using split-half and Cronbach's alpha methods as 0.94 and 0.91, respectively. In Iran, Hussein (2021) reported a total reliability of 0.74 using Cronbach's alpha (Kakavand & Rezaei, 2021). The reliability of the Emotional Intelligence Questionnaire in the current study was calculated using Cronbach's alpha, through the correlation coefficient between its items, as 0.90.

2.3. Data Analysis

In this study, data analysis was conducted using Pearson correlation coefficients and structural equation modeling in SPSS-27 and AMOS-24 software.

3. Findings and Results

In this study, 70.7% of the samples were female students, and 29.3% were male students. Table 1 presents the results of mean, standard deviation, skewness, and kurtosis of social competency, self-efficacy, and collective identity among students.

Table 1

Mean, Standard Deviation, Skewness, and Kurtosis of Social Competency, Self-efficacy, and Collective Identity among Students

Variables	Mean	Standard Deviation	Skewness	Kurtosis
Tangible Support	15.45	3.91	-0.652	-0.182
Emotional Support	14.17	4.10	-0.296	-0.867
Informational Support	14.37	3.71	-0.146	-0.591
Affection	11.46	3.09	-0.537	-0.557
Positive Social Interaction	11.53	3.20	-0.590	-0.526
Perceived Social Support	66.98	14.94	-0.311	-0.666
Self-awareness	12.05	4.06	0.915	1.07
Self-management	18.62	5.15	0.333	-0.146
Self-motivation	14.76	4.02	0.291	-0.273
Social Skills	11.28	3.69	0.431	-0.185
Social Awareness	8.96	2.60	0.144	-0.152
Emotional Intelligence	65.68	15.95	0.276	-0.277
Ethnic Identity	30.13	7.10	-0.172	-0.524
National Identity	39.82	9.07	-0.840	0.143
Transnational or Cosmopolitan Identity	29.42	4.68	-0.759	-0.158
Collective Identity	99.37	16.58	-0.459	-0.401

According to the results in Table 1, the assumption of normality for all variables was not rejected due to the skewness and kurtosis values being within the range of -2 to +2. Also, the assumption of no multicollinearity for perceived social support and emotional intelligence was not

rejected based on the variance inflation factor values of 1.42 and 2.13, respectively, since they were less than 5. Table 2 presents the results of the correlation coefficients between perceived social support, emotional intelligence, and collective identity among students.

Table 2

Correlation Coefficients of Perceived Social Support, Emotional Intelligence, and Collective Identity among Students

Variables	Perceived Social Support	Emotional Intelligence	Collective Identity
Perceived Social Support	1	-	-
Emotional Intelligence	.45*	1	-
Collective Identity	.26*	.31*	1

*p<0.01

According to the results in Table 2, perceived social support, emotional intelligence, and collective identity among students had a positive and significant correlation (P<0.01). Table 3 presents the fit indices results for the

model of collective identity based on perceived social support with the mediating role of emotional intelligence among students.

Table 3

Fit Indices Results for the Model of Collective Identity Based on Perceived Social Support with the Mediating Role of Emotional Intelligence among Students

Indices (Fit Index)	Acceptable Value	Calculated Value	Result
R ² (Coefficient of Determination)	> 0.33 (Greater than 0.33)	0.46	Confirmed
GFI (Goodness of Fit Index)	> 0.90 (Greater than 0.90)	0.93	Confirmed
RMSEA (Root Mean Square Error of Approximation)	< 0.08 (Less than 0.08)	0.067	Confirmed
CFI (Comparative Fit Index)	> 0.90 (Greater than 0.90)	0.93	Confirmed
NFI (Normed Fit Index)	> 0.90 (Greater than 0.90)	0.91	Confirmed
IFI (Incremental Fit Index)	> 0.90 (Greater than 0.90)	0.92	Confirmed
AGFI (Adjusted Goodness of Fit Index)	> 0.90 (Greater than 0.90)	0.92	Confirmed

PGFI (Parsimonious Goodness of Fit Index)	> 0.70 (Greater than 0.70)	0.75	Confirmed
Chi-Square/df (Chi-Square to Degree of Freedom Ratio)	$1 \leq \text{Index} \leq 5$ (Between 1 and 5)	2.68	Confirmed

According to the observed results in Table 3, the model of collective identity based on perceived social support with the mediating role of emotional intelligence among students had a suitable fit. Figure 1 presents the results of structural equation modeling in the standard coefficient condition for

the model of collective identity based on perceived social support with the mediating role of emotional intelligence among students, and Table 4 presents the effects of the aforementioned model.

Table 4

Effects in the Standard Coefficient Condition for the Model of Collective Identity Based on Perceived Social Support with the Mediating Role of Emotional Intelligence among Students

Effects	Standard Coefficient	t-Value	p-Value	Result
Effect of Perceived Social Support on Emotional Intelligence	0.43	9.06	< 0.001	Confirmed
Effect of Perceived Social Support on Collective Identity	0.59	13.26	< 0.001	Confirmed
Effect of Emotional Intelligence on Collective Identity	0.30	6.95	< 0.001	Confirmed
Indirect Effect of Perceived Social Support through Emotional Intelligence on Collective Identity	0.12	5.56	< 0.001	Confirmed

Figure 1

The Results of Qualitative Analysis

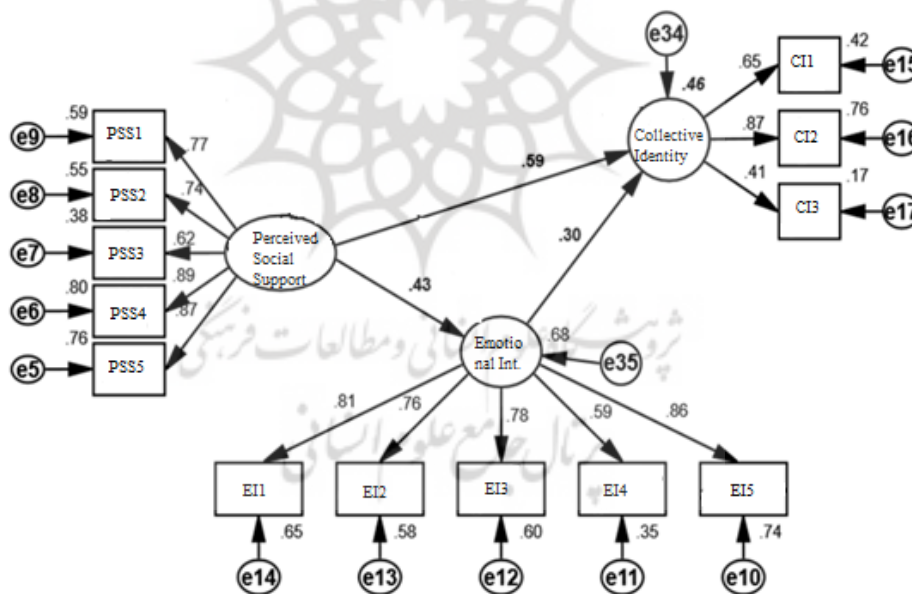

According to the results observed in Figure 1 and Table 4, in the model of collective identity based on social competency with the mediating role of self-efficacy among students, the variable of perceived social support had a direct and significant effect on emotional intelligence and students' collective identity, and the variable of emotional intelligence had a direct and significant effect on their collective identity. Perceived social support with the mediating role of

emotional intelligence had an indirect and significant effect on students' collective identity ($P < 0.001$).

4. Discussion and Conclusion

Given the significance of collective identity in group and social activities, this study aimed to design a model of

collective identity based on perceived social support with the mediating role of emotional intelligence among students.

The first finding of this study showed that perceived social support had a direct and significant effect on students' emotional intelligence. This finding aligns with the results of prior studies (Azpiazu et al., 2023; Ghazvineh et al., 2022; Taleghaninejad et al., 2021; Ullah et al., 2023) regarding the effect of perceived social support on emotional intelligence. It can be inferred that individuals with social support feel a greater sense of duty and commitment to others and have a higher level of collective identity because they possess a sense of social life in their socialization process. Sources of perceived social support are diverse and varied, with the family environment being the primary source of social support experiences, along with peers, friends, relatives, and colleagues. Perceived social support refers to the care, affection, esteem, and assistance provided by others or groups to an individual, and undoubtedly, those with higher social and emotional understanding receive more social support. Consequently, perceived social support can have a direct and significant effect on students' emotional intelligence.

The second finding of this study showed that perceived social support had a direct and significant effect on students' collective identity. This finding is consistent with the results of prior studies (Haslam et al., 2005; Häusser et al., 2023; Majdi et al., 2016) regarding the effect of perceived social support on collective identity. It can be deduced that social convergence relates to an individual's connections with significant others in the social environment and their sense of belonging to social groups, primarily assessed through social relationships with a spouse, family, friends, and participation in organizations. Perceived social support is determined by cognitive assessments of being reliably connected to others and evaluates an individual's perceptions of the availability of support in times of need and necessity. Not all relationships that an individual has are considered social support unless the individual views them as a suitable source for addressing their problems and needs. Those who receive support feel loved, cared for, respected by others, and consider themselves part of a social network of family, friends, and organizations that can be a source of material and spiritual help and mutual services when needed. Therefore, perceived social support can have a direct and significant effect on students' collective identity.

The third finding of this study showed that emotional intelligence had a direct and significant effect on students' collective identity. This finding aligns with the results of

prior studies (Canto & Vallejo-Martín, 2021; Esmaeilshad et al., 2021) regarding the effect of emotional intelligence on collective identity. It can be inferred that emotional intelligence, the ability to control feelings and emotions in oneself and others and use them to guide thoughts and behaviors, helps individuals cope with environmental stressors. Emotional intelligence, with components like self-awareness, self-management, self-motivation, social skills, and social awareness, plays a significant role in improving life situations and feelings of belonging to a group and society. Individuals with high emotional intelligence have the ability to understand, facilitate, discern, and regulate their own and others' emotions and are more inclined to join various groups. Consequently, their interactions with others are more effective and efficient, providing them with ample opportunities to establish intimacy, empathy, and positive friendship experiences, successfully navigate various problems and challenges, and present themselves as group members. As a result, emotional intelligence can have a direct and significant effect on students' collective identity.

The fourth finding of this study showed that perceived social support, with the mediating role of emotional intelligence, had an indirect and significant effect on students' collective identity. No research was found on this aspect, but it can be inferred that social support is a network that provides psychological resources for individuals to cope with life's stressors and daily problems. Social support, a mutual aid, creates a positive self-image, self-restraint, feelings of love and self-esteem, all of which enhance emotional intelligence. Additionally, individuals and groups with supportive behavior can focus on emotional and emotional needs, creating a friendly environment where individuals can freely express their ideas and interact with others. Moreover, individuals with high emotional intelligence have unique characteristics, making it easier for them to establish connections with others, possess logical thoughts, express their feelings, and better understand others' emotions, all of which can positively affect collective identity. Therefore, emotional intelligence can serve as an appropriate mediator between perceived social support and collective identity, and perceived social support can have an indirect and significant effect on students' collective identity with the mediating role of emotional intelligence.

This study was conducted solely among psychology students at the Islamic Azad University of Qom Province, where some confounding variables, such as gender, were not controlled. Another limitation was the use of a non-random convenience sampling method and the lack of gender-

specific analysis. Therefore, conducting research on students from other disciplines and universities is recommended. Another suggestion is to analyze results by gender, as gender affects many characteristics, and the last suggestion is to use random sampling due to lower sampling error. Based on the results of this study, counselors and psychologists can improve students' collective identity by enhancing their perceived social support and emotional intelligence through educational workshops.

Authors' Contributions

In this study, the authors collectively were responsible for data collection, analysis, and manuscript writing.

Declaration

In order to correct and improve the academic writing of our paper, we have used the language model ChatGPT.

Transparency Statement

Data are available for research purposes upon reasonable request to the corresponding author.

Acknowledgments

This study acknowledged all those who contributed to its completion.

Declaration of Interest

No conflict of interest was reported.

Funding

According to the authors, this article has no financial support.

Ethical Considerations

This study adhered to ethical principles such as confidentiality and voluntary participation.

References

- Ahmadi, F., & Amoopour, M. (2023). Predicting academic self-disability based on social support and mental health in students. *Journal of Educational Psychology*, 1(14), 1-9. <http://sanad.iau.ir/fa/Article/953496>
- Ayar, D., & Sabancıoğulları, S. (2022). The effect of a solution-oriented therapy on the depression levels and the perceived social support of depressive patients. *Arch Psychiatr Nurs*, 36, 62-69. <https://doi.org/10.1016/j.apnu.2021.11.004>
- Azpiazu, L., Antonio-Agirre, I., Fernández-Zabala, A., & Escalante, N. (2023). How does social support and emotional intelligence enhance life satisfaction among adolescents? A mediational analysis study. *Psychology research and behavior management*, 2341-2351. <https://doi.org/10.2147/PRBM.S413068>
- Babanejad, F., Shams Esfandabad, H., & Namvar, H. (2020). Investigate the Mediating Role of Attitudes to Cheating in the Relationship between Social Support and Educational Justice with Cheating Behavior [Research Article]. *Iranian Journal of Educational Sociology*, 3(3), 88-96. <https://doi.org/10.52547/ijes.3.3.88>
- Bein, S. (2022). How Is Collective Identity Possible in Democracies? Political Integration and the Leitkultur Debate in Germany. *Politische Vierteljahresschrift*, 63(1), 1-23. <https://doi.org/10.1007/s11615-021-00365-4>
- Buursma, M. P., Tintle, N. L., Boven, E., DeVon, H. A., & Dunn, S. L. (2020). Lack of perceived social support in patients with ischemic heart disease is associated with hopelessness. *Archives of Psychiatric Nursing*, 34(2), 14-16. <https://doi.org/10.1016/j.apnu.2019.12.001>
- Canto, J. M., & Vallejo-Martín, M. (2021). The Effects of Social Identity and Emotional Connection on Subjective Well-Being in Times of the COVID-19 Pandemic for a Spanish Sample. *International journal of environmental research and public health*, 18(19), 10525. <https://doi.org/10.3390/ijerph181910525>
- Encinas, J. J., & Chauca, M. (2020). Emotional intelligence can make a difference in Engineering Students under the Competency-based Education Model. *Procedia Computer Science*, 172, 960-964. <https://doi.org/10.1016/j.procs.2020.05.139>
- Esmailshad, B., Soleimanpour Omran, M., & Soheilifar, F. (2021). The relationship between social identity and job self-efficacy with the mediating role of emotional intelligence in preschool teachers. *Biannual Journal of Psychological Research in Management*, 7(1), 90-111. https://jom.hmu.ac.ir/article_245870.html?lang=en
- Ghazvineh, J., Jadidi, H., Taghvaeinia, A., & Morovvati, Z. (2022). The effect of Emotional Intelligence, Self-Regulation and Assertiveness on Academic Satisfaction with mediation of Perceived Social Support in students of the second high school. *Journal of Research in Educational Systems*, 16(59), 49-62. https://www.jiera.ir/article_169448_en.html
- Haslam, S. A., O'Brien, A., Jetten, J., Vormedal, K., & Penna, S. (2005). Taking the strain: Social identity, social support, and the experience of stress. *British Journal of Social Psychology*, 44(3), 355-370. <https://doi.org/10.1348/014466605X37468>
- Häusser, J., Abdel Hadi, S., Reichelt, C., & Mojzisch, A. (2023). The reciprocal relationship between social identification and social support over time: A four-wave longitudinal study. *British Journal of Social Psychology*, 62(1), 456-466. <https://doi.org/10.1111/bjso.12553>
- Hezarjaribi, J., & Lohrasbi, S. (2011). The control of relationship between social capital and the rate of collective identity. *Journal of Applied Sociology*, 22(2), 1-20. https://jas.ui.ac.ir/article_18222_en.html
- Kakavand, M., & Rezaei, A. (2021). The Effect of Emotional Intelligence Dimensions on the Educational Achievement at Agricultural Students of Razi University, Iran. *Journal of Agricultural Education Administration Research*, 13(56), 73-90. <https://doi.org/10.22092/jaear.2021.354360.1822>
- Kann, C., Hashash, S., Steinert-Threlkeld, Z., & Alvarez, R. M. (2023). Collective identity in collective action: evidence from the 2020 summer BLM protests [Original Research].

- Frontiers in Political Science*, 5. <https://doi.org/10.3389/fpos.2023.1185633>
- Li, N., Li, S., & Fan, L. (2021). Risk Factors of Psychological Disorders After the COVID-19 Outbreak: The Mediating Role of Social Support and Emotional Intelligence. *Journal of Adolescent Health*, 69(5), 696-704. <https://doi.org/10.1016/j.jadohealth.2021.07.018>
- Liu, M., Xiao, J., Kamper-DeMarco, K. E., & Fu, Z. (2023). Problematic internet use and suicidality and self-injurious behaviors in adolescents: Effects of negative affectivity and social support. *Journal of affective disorders*, 325, 289-296. <https://doi.org/10.1016/j.jad.2023.01.019>
- Mackay, C. M. L., Schmitt, M. T., Lutz, A. E., & Mendel, J. (2021). Recent developments in the social identity approach to the psychology of climate change. *Current opinion in psychology*, 42, 95-101. <https://doi.org/10.1016/j.copsyc.2021.04.009>
- Majidi, A. A., Ramezani, H., & Azimi Hashemi, M. (2016). Investigating the Relationship between Social Support and Identity Formation: A Case Study of the Children of Martyrs in Neyshabur, Iran. *Journal of Social Sciences Ferdowsi University of Mashhad*, 13(1), 217-238. https://social.um.ac.ir/article/view/52668/article_26860.html?lang=en
- Malik, S. (2021). The nexus between emotional intelligence and types of knowledge sharing: does work experience matter? *Journal of Workplace Learning*, 33(8), 619-634. <https://doi.org/10.1108/JWL-10-2020-0170>
- Masoumparast, S., Zare Bahramabadi, M., Khoeini, F., & Moradi, H. (2019). A Causal Model of Psychological Well-being based on Social Capital through the Mediating role of Emotional Intelligence in Education Staff [Research Article]. *Iranian Journal of Educational Sociology*, 2(4), 134-142. <https://doi.org/10.29252/ijes.2.4.134>
- Millwood, S. N., & Manczak, E. M. (2023). Patterns of adolescent perceived social support and inflammation in adulthood within major racial groups: Findings from a longitudinal, nationally representative sample. *Brain, behavior, and immunity*, 110, 95-106. <https://doi.org/10.1016/j.bbi.2023.02.017>
- Taleghaninejad, M., Davari, R., & Lotfikashani, F. (2021). Prediction of Internet addiction based on perceived social support, stress coping styles and emotional intelligence in students. *Information and Communication Technology in Educational Sciences*, 11(3), 109-129. https://ictedu.sari.iau.ir/article_680416.html?lang=en
- Torun, T., Çavuşoğlu, H., Doğru, D., Özçelik, U., & Tural, D. A. (2021). The effect of self-efficacy, social support and quality of life on readiness for transition to adult care among adolescents with cystic fibrosis in Turkey. *Journal of Pediatric Nursing*, 57, e79-e84. <https://www.sciencedirect.com/science/article/pii/S0882596320306655>
- Ullah, M. S., Akhter, S., Aziz, M. A., & Islam, M. (2023). Social support: mediating the emotional intelligence-academic stress link [Original Research]. *Frontiers in psychology*, 14. <https://doi.org/10.3389/fpsyg.2023.1218636>
- Ulug, C., Horlings, L., & Trelle, E.-M. (2021). Collective Identity Supporting Sustainability Transformations in Ecovillage Communities. *Sustainability*, 13(15), 8148.
- White, B. A. A., Fleshman, J. W., Picchioni, A., Hammonds, K. P., Gentry, L., Bird, E. T., Arroliga, A. C., & Papaconstantinou, H. T. (2023). Using an Educational Intervention to Map our Surgical Teams' Function, Emotional Intelligence, Communication and Conflict Styles. *Journal of Surgical Education*, 80(9), 1277-1286. <https://doi.org/10.1016/j.jsurg.2023.06.001>
- Xiao, Y., Ran, H., Fang, D., Che, Y., Donald, A. R., Wang, S., Peng, J., Chen, L., & Lu, J. (2022). School bullying associated suicidal risk in children and adolescents from Yunnan, China: The mediation of social support. *Journal of affective disorders*, 300, 392-399. <https://doi.org/10.1016/j.jad.2022.01.032>